

Rainwater harvesting for multi-dwelling developments



- Tanks 1500 - 6500 litres and bigger
- Huge stock for immediate delivery
- Ground-stabilised shallow dig available
- No concrete, quick install
- Direct or Gravity feed
- Save costs with shared tanks
- Revolutionary Rain Director®
- Specs and quotes by our experts



Rain Backup in a Box®

DIRECT FEED, ONE TANK PER DWELLING

Direct feed. The simplest specification for a multi-dwelling development is one underground tank and filter per dwelling, with a submersible pump maintaining pressure directly to the toilets and washing machine. When an occupant flushes, it pumps. If the rainwater runs out, a float switch triggers a valve in each dwelling to run some mains water into the underground tank

so that the appliances continue to work. The bulk of the tank is left empty to receive the next rain storm. See our documentation on direct feed systems and the **Rain Backup in a Box®**.

At the core of our offer is the highly-acclaimed range of Carat, Rondus and Platin underground tanks from

German manufacturer Graf in sizes from 1500 to 6500 litres. They have the advantage of strength of build, long life, easy to install features and simple connection of multiple tanks to make industrial scale volumes at mass production prices.

 Full function



Smart header tank in each dwelling



Rain Director® in each dwelling



GRAVITY FEED, ONE TANK PER DWELLING

Gravity Feed. Many experts prefer the use of a smart header tank in the roof space to provide the appliances with rainwater by gravity, in our case the state-of-the-art **Rain Director®**. The advantages are that the submersible pump is not hunting against the appliances and only pumps when the header tank is empty. About 8 times less electricity is used than in a direct feed system. If the rainwater runs out, mains water flows to the header tank not the

underground tank. The user knows the status of the system, including whether mains or rain is being used, from the control panel indicator lights. Ask for our documentation on gravity feed systems and **The Rain Director®**.

Use of a dumb header tank (tank in the roof space with the float valve for mains water a few inches below the float valve for rainwater) is tempting but there

are several disadvantages. Notably, the rainwater in such a tank will be subject to bacterial action which needs warmth of 15°C or more... during the summer or vacations the water will go off and become discoloured. A mains water inlet must be provided with a means of complying with the Water Regulations obligation to prevent contamination of mains water by rainwater. **The Rain Director®** and its smart header tank solves these problems.



Requires landlord's feeds



Landlord's mains water backup and electricity supply

DIRECT FEED, SHARED TANK

Direct feed. One tank per dwelling is not the cheapest way to install rainwater harvesting, neither the equipment nor the groundworks and plumbing. That's why on these two pages we show how a storage tank can be shared between dwellings to save costs, typically up to 40%.

With a direct feed system, sharing of the pump means that the electricity to run the pump must be supplied from and charged to a landlord's supply (although a pump for each dwelling could be installed in the shared tank). Furthermore when the rain runs out the cost of the mains water used when rainwater runs out would

have to be shared out among the dwellings or charged to a landlord's account. This is acceptable for social housing with tenants only, but not for a development where some properties might be sold.



Full function, 30-40% savings



Smart header tank in each dwelling



Rain Director® in each dwelling



GRAVITY FEED, SHARED TANK

Gravity feed is the ideal solution with a shared tank. **The Rain Director®** with its smart header tank and wall-mounted control panel is the key to impressive savings by sharing an underground rainwater storage tank between more than one dwelling. Using a shared rainwater tank, the rainwater itself is a communal resource shared between several dwellings. Each dwelling having a separate pump in the underground

tank means that the electricity is billed to the dwelling's own meter. Furthermore, if the rainwater runs out, mains water is admitted to the dwelling's own smart header tank so the mains water is also billed to the appropriate dwelling.

This solution enables savings of 30 to 40% in the total equipment and groundworks bills (the cost of the

underground tanks themselves is the biggest factor, and digging one bigger hole instead of many is cheaper). Potential disagreement between tenants is avoided. In the case of resale of one of the dwellings in the block with a shared tank, this is made easier by the individual billing of electricity and mains water for backup.

Expertise, quotes , support

In quoting for your development we can help you meet the requirements of the UK Building Regulations, the Code for Sustainable Homes levels 3 or 4 or better, BRE, the water companies' requirements (WRAS), British standard BS 8515-09 and international quality standards ISO9001 Design & Build, EN976, EN858, TÜV or CE. Most of our products are listed on the Water Technology List (WTL), which provides information on water-saving products that qualify for up-front tax relief for commercial companies. Aspects of storm attenuation and SUDS can be built into the spec.

Our systems come with installation instructions and engineering details such as the CAD CAM drawings of each aspect of the tank. See below the Carat 2700 litre showing outer dimensions and the alternative positions of the 4 inch holes for the filter and overflow siphon.

Most of our tanks including the world-beating GRAF Carat range are strong enough not to require encasing in concrete (unless the ground conditions demand it). This greatly reduces the cost of installation. The flat shapes of the GRAF Platin and Rondus tanks permit a shallow dig and further groundworks costs savings. The filters are self cleaning and much of the equipment maintenance free.

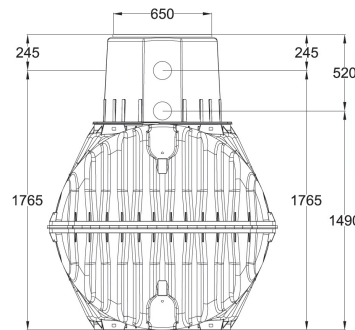
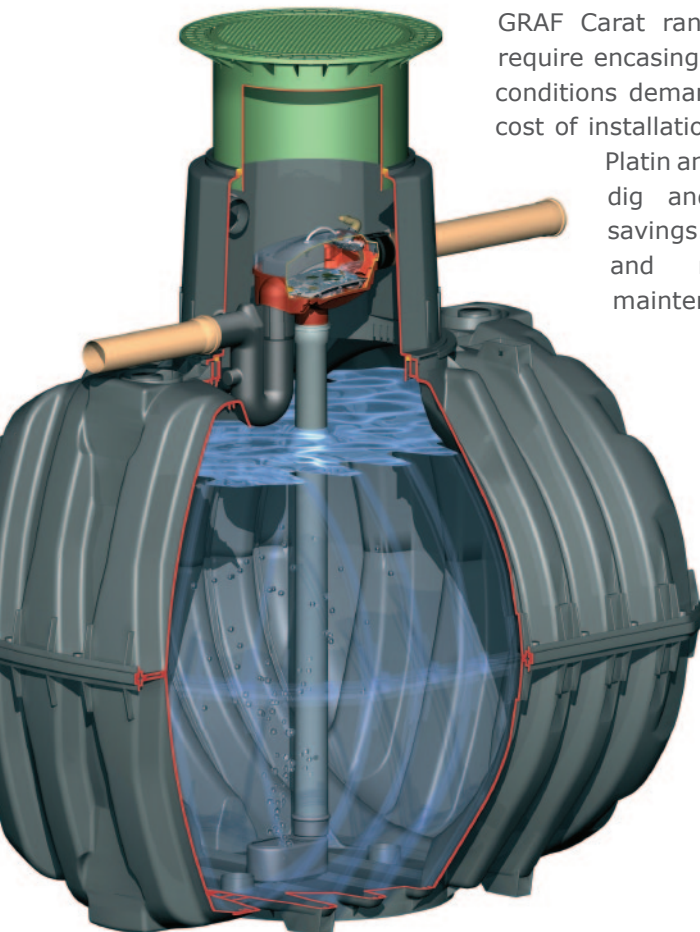

The Rain Director®

We are the company which has introduced the revolutionary new **Rain Director®**. You need to ensure mains water runs to your appliances if the rainwater runs out but you need to avoid shortcomings in some other mains backup products on the market. **The Rain Director®** has a small 91-litre roof-space header tank, electronic control unit which activates mains water and rainwater valves and suitable pump. This means you get:

- Fail-safe mains backup when rainwater runs out
- Less pump cycles, saves energy, prolongs pump life
- No stale or yellow water
- Assured water supply during power cuts
- Automatic and user-controlled functions e.g. holiday and flush modes.



Sharing the underground storage tank: impact on billable resources

	Direct Feed			Rain Director® System ¹		
	Rainwater	Pump electricity	Mains water	Rainwater	Pump electricity	Mains water
One system per home	Own	Own	Own	Own	Own	Own
Storage tank shared between homes, own pump	Shared ³	Own	Shared ²	Shared ³	Own	Own
Storage tank and pump shared between homes ⁵	Shared ³	Shared ⁴	Shared ²	Shared ³	Shared ⁴	Own

Equipment and connections to the building in each case

	Direct Feed			Rain Director® System ¹		
	Rainwater	Pump electricity	Mains water	Rainwater	Pump electricity	Mains water
One system per home	Own underground tank. 32 or 25mm MDPE to home	Own pump. Cable from home to tank	Backup device in each home, 25mm to tank	32 or 25mm MDPE to home	Cable from home to tank	Mains water to header via control panel
Storage tank shared between homes, own pump	Pump in underground tank for each dwelling. 32 or 25mm MDPE to home	Pump in underground tank for each dwelling. Cable from home to tank	Backup device in landlord locale, to tank	Pump in underground tank for each dwelling. 32 or 25mm MDPE to home	Cable from each home to tank	Mains water to header via control panel
Storage tank and pump shared between homes	Shared tank and pump. 32 or 25mm MDPE teed off to each home	Cable from landlord locale to tank	Backup device in landlord locale, pipe to tank	Shared underground tank. 32 or 25mm MDPE teed off to each home	Cable from landlord locale to tank	Mains to header via control panel

Key to footnotes in table

- The Rain Director®** includes smart header tank, control panel and submersible pump.
- When rainwater runs out, direct feed systems require a small amount of mains water to be admitted to the underground storage tank on a float switch. Landlord's water supply required.
- Rainwater can be considered a communal resource and communicated to occupants as such.
- Landlord's electricity supply required
- One pump maintains pressure to all dwellings.



Text in **green** in the tables shows an ideal solution, while **red** shows shared electricity or mains water.



Rainwater Harvesting is a Must

- a) The **Code for Sustainable Homes** requires social housing to meet level 3, reducing mains water consumption to 85 litres per person per day by using rainwater harvesting and water efficient appliances.
- b) **Building Regulations Part G** will change in April 2010 to enforce a limit of 125 litres mains water consumption per head per day in new-builds.
- c) Councils look favourably on **planning applications** with rainwater harvesting.
- d) **Flood Attenuation.** Planners now encourage and impose rainwater harvesting to alleviate flood threats.
- e) Businesses can benefit from the **Enhanced Capital Allowance**: 100% of costs of rainwater harvesting systems registered on Water Technology List can be offset against tax liability.
- f) New legislation will give water boards greater **hosepipe ban** powers during water shortages.
- g) **DEFRA** can impose even more severe drought restrictions at any time.
- h) **British Standard 8515** of February 2009 recommends standards of installation of rainwater harvesting.

Professional Service From RainWater Harvesting Ltd

- **Specification:** You have initial architects' plans and you'd like to have RainWater Harvesting Ltd write a complete specification. To be able to specify the right equipment for the project please email us the following data:
 - 1) roof dimensions in metres or total area in square metres.
 - 2) part of the UK in which building is situated.
 - 3) the number of people using the dwelling.
- **Tank size calculation:** We are always very keen to do the best job for you and this includes checking the storage tank size against the new British standard for rainwater harvesting BS 8515/2009.
- **Compliance:** All our products are conceived and manufactured to BS 8515 - 2009 and WRAS standards including the A-A and A-B air gaps required. Our Rain Director® is the only rainwater management system to have WRAS approval.
- **Installation instructions** including advice on tank size, filter choice, drains, soakaway, flood attenuation, hole size, internal options and fittings, mains backup, direct or gravity options, smart header tank options, maintenance, incentives and regulations.
- **Delivery:** shipping of complete tank systems to mainland Britain is by our trucks from our warehouse in Peterborough. The Carat tanks, whose two pieces enable them to be stacked more effectively, increase the numbers per truck and therefore reduce delivery costs.
- **Installation and after-sales support:** email and immediate phone support for the contractor or installer is available both during installation and afterwards.



Telephone: 01733 405111

Fax: 01733 230996

info@rainwaterharvesting.co.uk

www.rainwaterharvesting.co.uk

RainWater Harvesting Limited
Unit A Harrier Park
Southgate Way
Orton Southgate
Peterborough
PE2 6YQ

Registered Number: 3967275
VAT No GB 940 8955 90

