

Installation and maintenance instructions for GRAF rainwater storage tank, Carat -S- series

2700 L **Order No. 372024**
700 US-gallons

3750 L **Order No. 372025**
1000 US-gallons

4800 L **Order No. 372026**
1250 US-gallons

6500 L **Order No. 372027**
1700 US-gallons



The points described in these instructions must be observed under all circumstances. All warranty rights are invalidated in the event of non-observance. Separate installation instructions are enclosed in the transportation packaging for all additional articles purchased from GRAF.

Missing instructions must be requested from us immediately.

The tank must be checked for any damage prior to insertion into the trench under all circumstances.

Installation must be carried out by a specialist company.

Table of contents

1. GENERAL NOTES	2
1.1 Safety	2
1.2 Identification obligation	2
2. INSTALLATION CONDITIONS	3
3. TECHNICAL DATA	4
4. TANK STRUCTURE	5
5. INSTALLATION AND ASSEMBLY	5
5.1 Tank assembly	6
5.2 Construction site	6
5.3 Trench	7
5.4 Insertion and filling	8
5.5 Routing connections	8
6. ASSEMBLING THE TANK DOME AND TELESCOPIC DOME SHAFT	9
6.1 Assembling the tank dome	9
6.2 Assembling the telescopic dome shaft	9
6.3 Telescopic dome shaft on which persons may walk	9
6.4 Telescopic dome shaft over which passenger cars may drive	9
6.5 Assembling the adapter	10
7. INSPECTION AND SERVICING	10

1. General notes

1.1 Safety

The relevant accident prevention regulations must be observed during all work. Particularly when walking on the tanks, a 2nd person is required to secure the tank.

The relevant regulations and standards must additionally be taken into consideration during installation, assembly, servicing, repair, etc.

The system or individual parts of the system must be installed by qualified specialists.

During all work on the system or parts of the system, the entire system must always be rendered inoperable and secured to prevent unauthorised reactivation.

Except in the event of work carried out in the tank, the cover of the tank must always be kept sealed, as this otherwise constitutes a maximum risk of accident. Only original GRAF covers or covers approved in writing by GRAF must be used.

GRAF offers an extensive range of accessories, all of which are designed to match each other and which can be extended to form complete systems. The use of other accessories may lead to impediments to the system's functional capability, therefore invalidating liability for resulting damage.

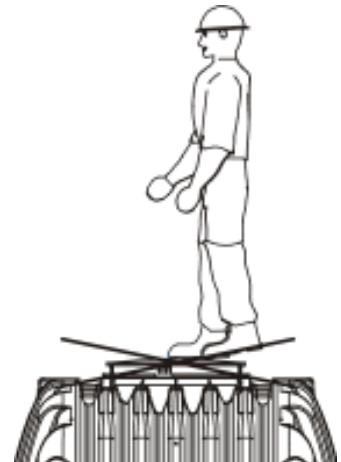

1.2 Identification obligation

All service water pipes and outlets must be identified in writing with the words "**Not drinking water**" or in the form of images in order to avoid inadvertent connection with the drinking water mains even after a number of years. Mix-ups, e.g. by children, may still occur even in the case of correct identification. All service water extraction points must therefore be installed with valves with **child-proof locks**.

2. Installation conditions

Coverage heights with telescopic dome shaft in green areas.

The mini dome shaft produces a depth of cover of between 420 – 620 mm.

Maximum coverage heights with intermediate section and telescopic dome shaft.

(in green areas only, without groundwater and stratum water)

Coverage heights with cast telescopic dome shaft (class B) in areas used by passenger cars.

(without groundwater and stratum water)

The Carat – S series tanks must not be installed below areas used by vehicles which are heavier than passenger cars.

The Carat – S series tanks must not be installed below areas used by vehicles which are heavier than passenger cars.

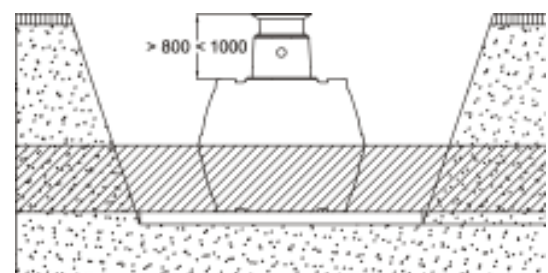
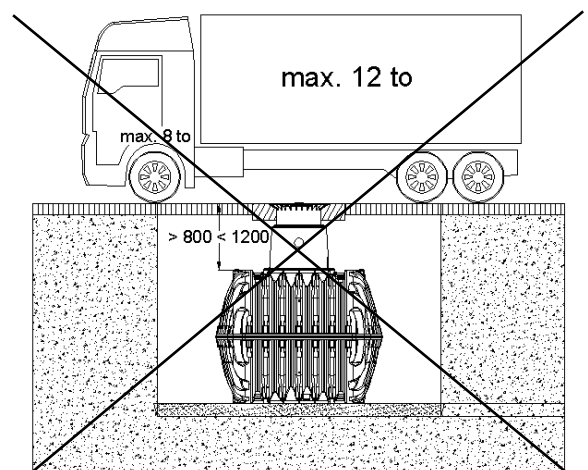
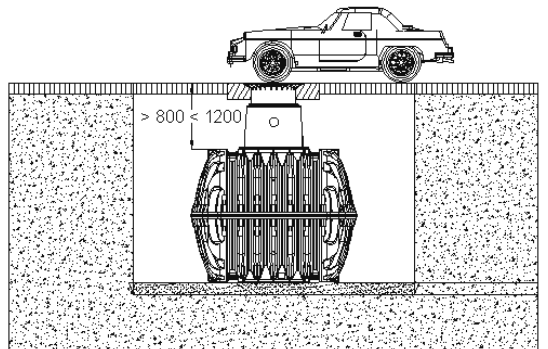
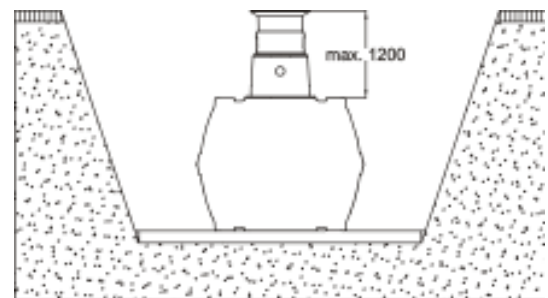
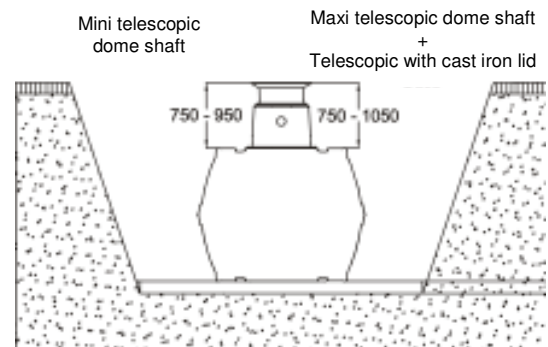

3. Technical data

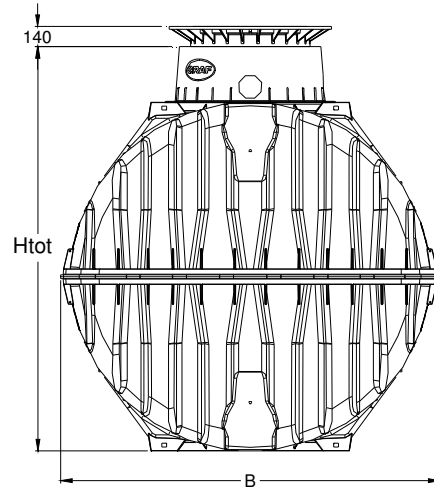
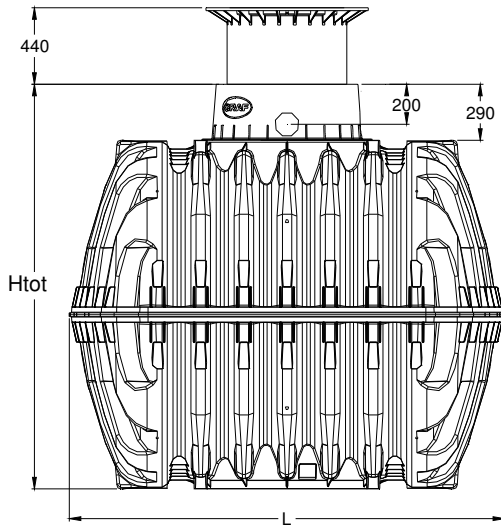

with tank dome Mini

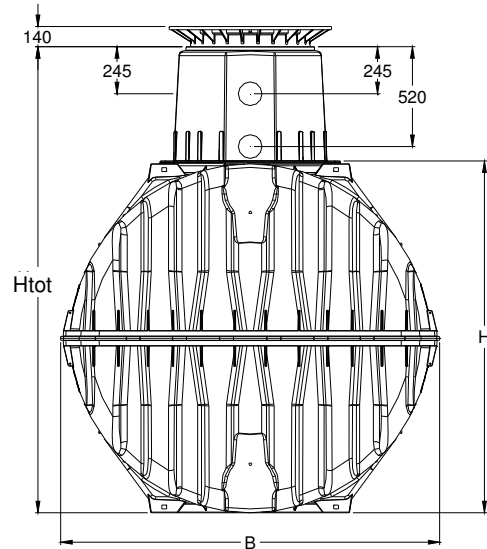
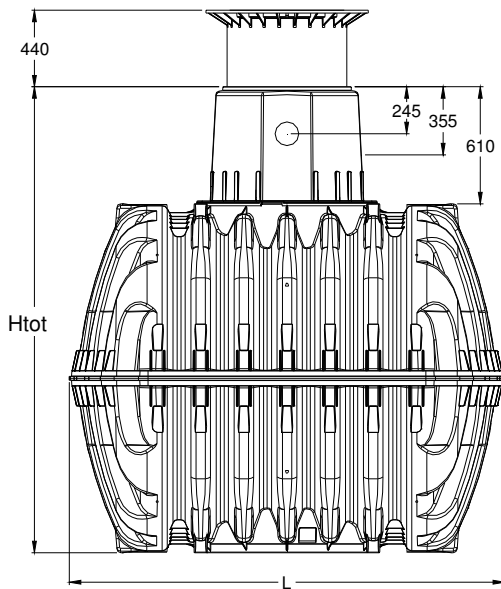

with tank dome Maxi

Tank	2700 litres 700 US-gallons	3750 litres 1000 US-gallons	4800 litres 1250 US-gallons	6500 litres 1700 US-gallons
Art. No.	370001	370002	370003	370004
Weight	120 kg	150 kg	185 kg	220 kg
L	2080 mm	2280 mm	2280 mm	2390 mm
W	1565 mm	1755 mm	1985 mm	2190 mm
H	1400 mm	1590 mm	1820 mm	2100 mm
Htot*	2010 mm	2200 mm	2430 mm	2710 mm
Htot** with mini tank dome	1680 mm	1870 mm	2100 mm	2380 mm

* Htot = total height

4. Tank structure

① Cover

② Telescopic dome shaft (can be inclined by 5°)

③ Profile seal

④ Tank dome (can be rotated by 360°)

⑤ Tank - tank dome seal

⑥ Carat underground tank

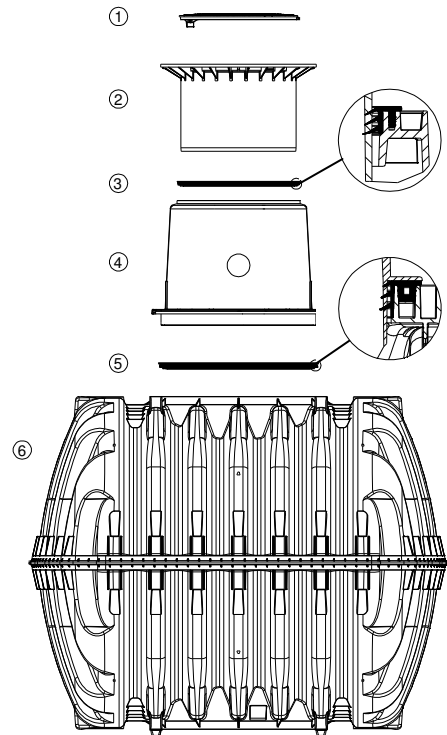

5. Installation and assembly

① Subsoil

② Telescopic dome shaft

③ Compacted foundation

④ Surrounding (round-grained gravel, max. grain size 8/16)

⑤ Covering layer

⑥ Carat underground tank

⑦ Concrete layer for surfaces used by passenger cars

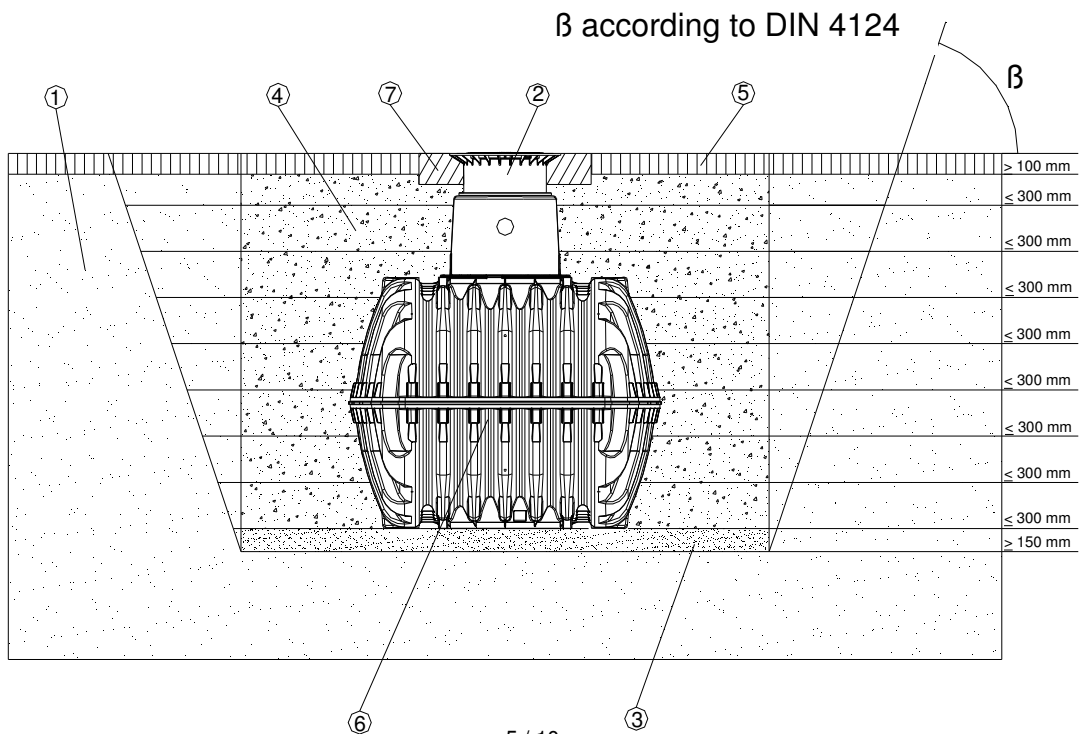

5. Installation and assembly

5.1 Tank assembly

First insert the circumferential profile seal ② into the sealing groove in the lower half shell ①. Lightly coat the seal with the enclosed soft soap.

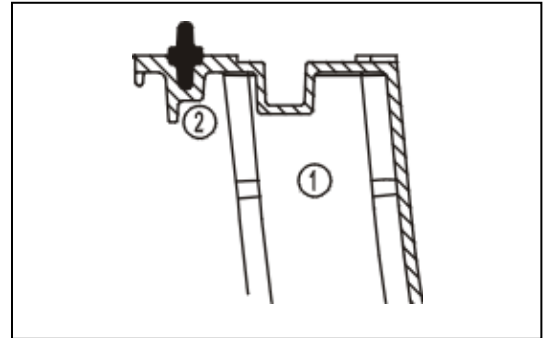

Then insert the centring pins ③ into the intended mountings around the circumference.

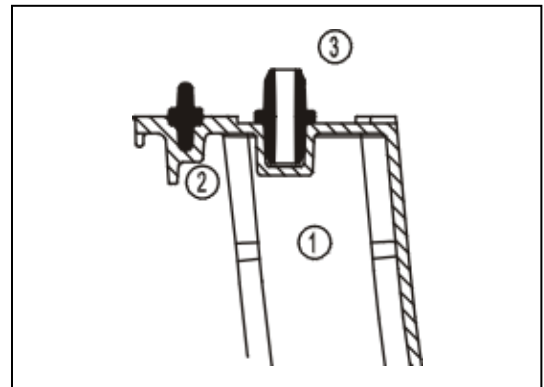

The upper half shell ④ is now positioned onto the lower half shell ① and the quick connectors ⑤ are installed. To do this, each 2nd quick connector is pre-adjusted in the 1st step and is secured with a hammer and a wooden support. The quick connectors engage in their end position. The remaining quick connectors are then installed.

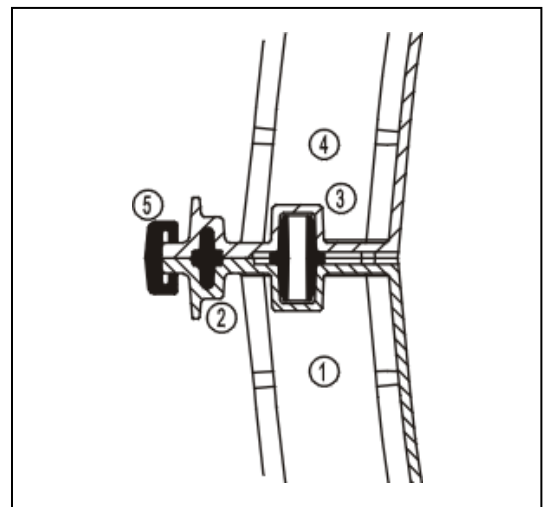

Attention: When positioning the upper half shell, it must be ensured, under all circumstances, that the seal does not slip out of the groove.

5.2 Construction site

Under all circumstances, the following points must be clarified prior to installation:

- The structural suitability of the ground according to DIN 18196
- Maximum groundwater levels which occur and drainage capability of the subsoil
- Types of load which occur, e.g. traffic loads

An expert ground report should be requested from the local planning authority to determine the physical characteristics of the subsoil.

5. Installation and assembly

5.3 Trench

To ensure that sufficient space is available for working, the base area of the trench must exceed the dimensions of the tank by 500 mm on each side; the distance from solid constructions must be at least 1000 mm.

The trench embankment must be designed so that slippage or collapse of the embankment wall is not to be anticipated. The construction site must be horizontal and plane and must guarantee sufficient load-bearing capacity.

The depth of the trench must be dimensioned so that the max. earth coverage (see point 2 – installation conditions) above the tank is not exceeded. To use the system throughout the entire year, it is necessary to install the tank and those parts of the system which conduct water in the frost-free area. The frost-free depth is usually approx. 600 mm – 800 mm; precise information in this regard can be obtained from the responsible authority.

A layer of compacted, round-grain gravel (grain size 8/16, thickness approx. 150 - 200 mm) is applied as the foundation.

5.3.1 Slope, embankment, etc.

On installation of the tank in the immediate vicinity (< 5 m) of a slope, earthen mound or slope, a statically calculated supporting wall must be erected to absorb the soil pressure. The wall must exceed the dimensions of the tank by at least 500 mm in all directions, and must be located at least 1000 mm away from the tank.

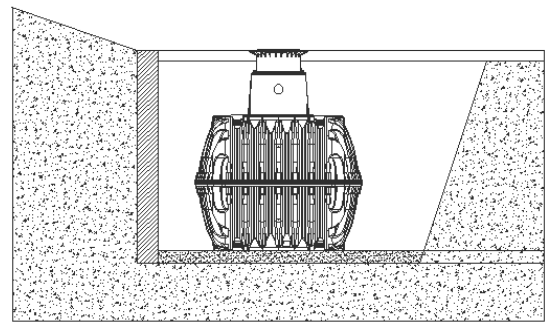

5.3.2 Groundwater and cohesive (water-impermeable) soils (e.g. clay soil)

If it is anticipated that the tanks will be immersed deeper into the groundwater than is shown in the adjacent figure, sufficient dissipation must be ensured. (See table for max. immersion depth).

Dissipation of the drainage water (e.g. via an annular drainage system) is recommended in the case of cohesive, water-impermeable soils.

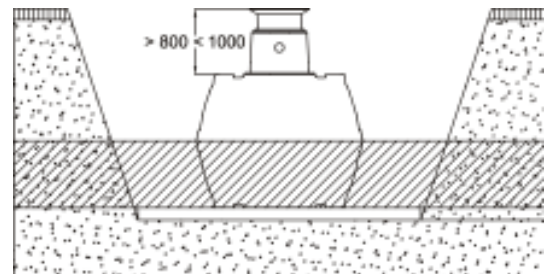

Tank size	2700 L 700 US-gallons	3750 L 1000 US-gallons	4800 L 1250 US-gallons	6500 L 1700 US-gallons
Immersion depth	700 mm	795 mm	910 mm	1050 mm

5.3.3 Installation adjacent to surfaces used by vehicles

If the underground tanks are installed adjacent to surfaces which are used by vehicles heavier than passenger cars, the minimum distance away from these surfaces is at least the depth of the trench.

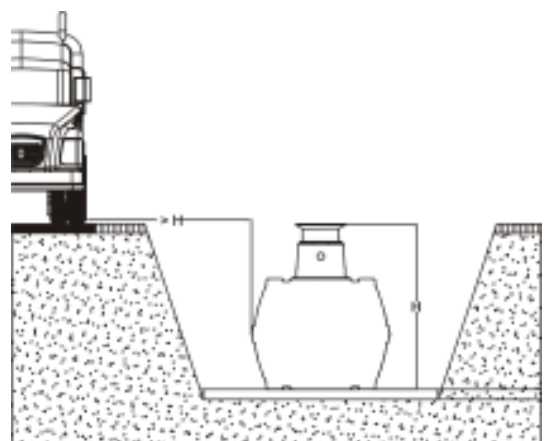

5. Installation and assembly

5.3.4 Connection of several tanks

Two or more tanks are connected via the assembly surfaces by means of GRAF special seals and basic pipes (to be provided at construction site).

The apertures must be drilled to the corresponding size using only the GRAF special crown bit. It must be ensured that the distance between the tanks is at least 600 mm. The pipes must project at least 200 mm into the tanks.

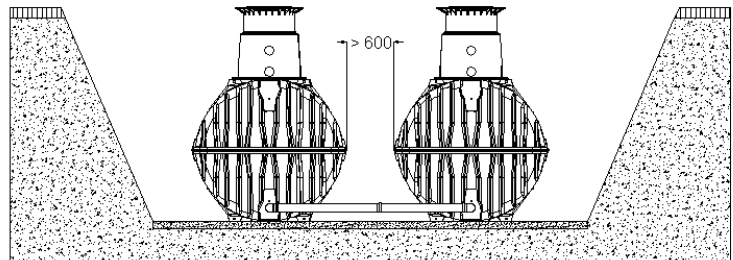

5.4 Insertion and filling

The tanks must be inserted, impact-free, into the prepared trench using suitable equipment. To avoid deformities, the tank is filled 1/3 with water before filling in the tank surrounding.

Afterwards the surrounding (roundgrain gravel, max. grain size 8/16) is then filled in layers of max. 30 cm steps and is compacted. The individual layers must be well-compacted (manuel tamper). Damage to the tank must be avoided during compaction. Mechanical compaction machines must not be used under any circumstances. The surrounding must be at least 500 mm wide.

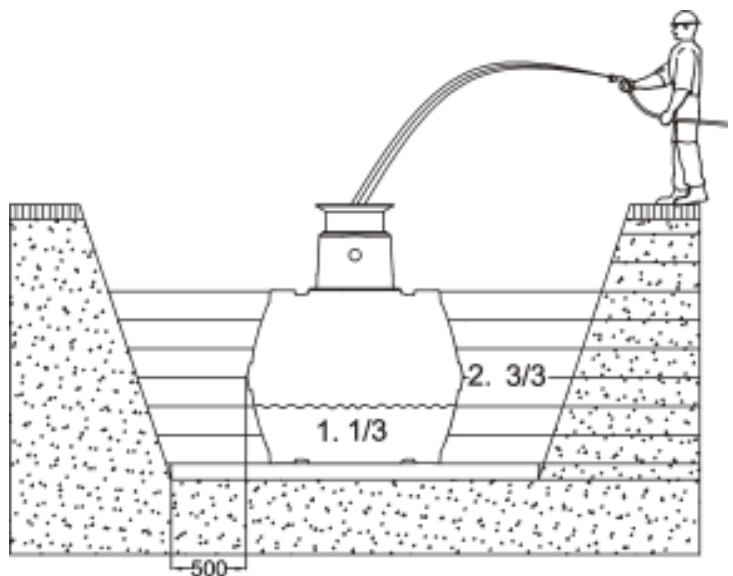

5.5 Routing connections

All feed and overflow pipes must be routed with a decline of at least 1% in the direction of flow (possible, subsequent settling must be taken into consideration in this case). If the tank overflow is connected to a public sewer, this must be protected against reflux by means of a lifting station (mixed sewer) or reflux seal (pure rainwater sewer) according to DIN 1986.

All suction, pressure and control lines must be routed in an empty pipe, which must be routed as straight as possible, without bending, to the tank with a decline. Necessary bends must be formed using 30° moulded sections.

Important: The empty pipe must be connected to an aperture **above** the max. water level.

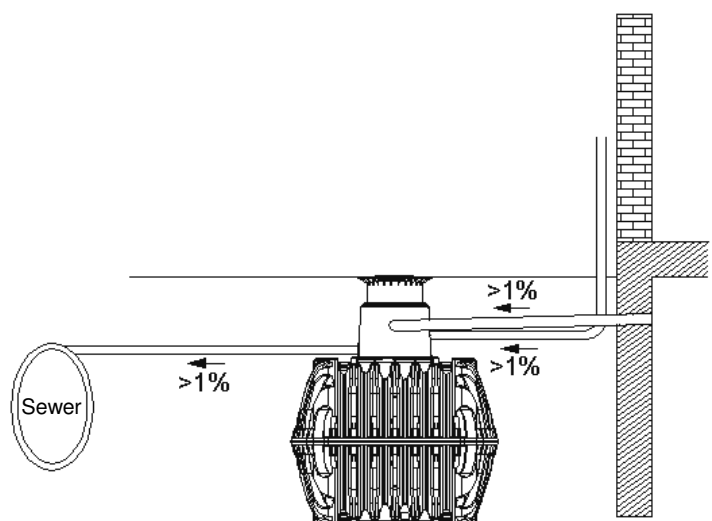

6. Assembling the tank dome and telescopic dome shaft

6.1 Assembling the tank dome

Prior to assembly, the enclosed seal is inserted into the tank domes' groove „B“. The tank dome is then aligned with the piping connections and is locked to the tank neck. It is essential to make sure that the upper seal "A" is correctly installed.

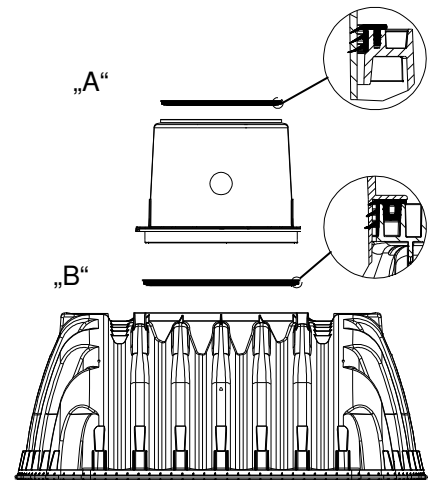
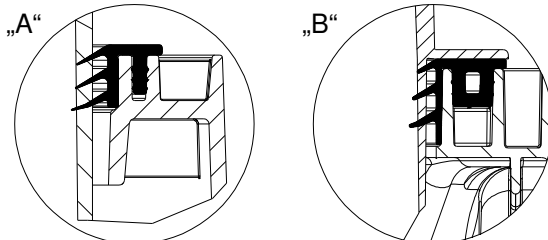

6.2 Assembling the telescopic dome shaft

The telescopic dome shaft enables infinite adaptation of the tank to given site surfaces with earth coverage of between 750 mm and 950 mm (Mini telescopic dome shaft) or 750 mm and 1050 mm (Maxi telescopic dome shaft).

For assembly purposes, the enclosed profile seal (material EPDM) is inserted into the tank dome's sealing groove and is coated generously with soft soap (do not use mineral oil-based lubricants, as these attack the seal). The telescope is then greased, inserted and aligned with the surface of the site.

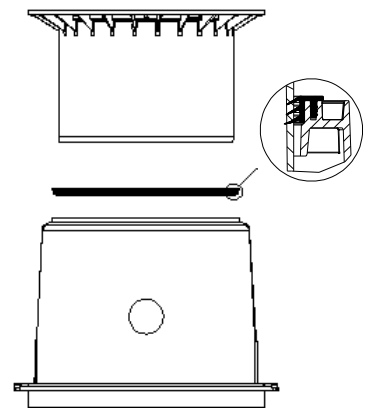

6.3 Telescopic dome shaft on which persons may walk

Important: To prevent loads from being transferred onto the tank, round-grain gravel ① (max. grain size 8/16) is filled in in layers around the telescope ② and is evenly compacted. Damage to the tank dome ③ and telescope must be avoided during this step. The cover is then positioned and is sealed to prevent entry by children. **Tighten the threaded connection on the cover so tightly that it cannot be opened by a child!**

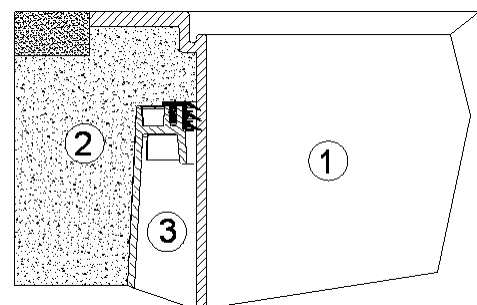

6.4 Telescopic dome shaft over which passenger cars may drive

If the tank is installed under areas used by passenger cars, the collar area of the telescope ① (colour anthracite) must be supported with concrete ④ (load class B25 = 250 kg/m²). The layer of concrete to be installed must be at least 300 mm wide and approx. 200 mm high all around. The minimum coverage above the shoulder of the tank is at least 800 mm (max. 1050 mm with telescope, coverage up to max. 1200 mm possible with intermediate section).

Attention: Use the cast cover under all circumstances.

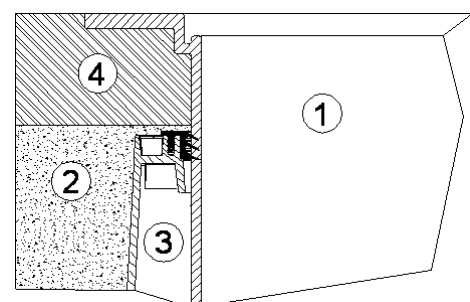

6. Assembling the tank dome and telescopic dome shaft

6.5 Assembling the adapter

For larger coverage heights an adapter is needed. To insert the adapter into the tank dome, soft soap is needed. Into the highest groove of the adapter the profile seal is inserted and greased generously. Afterwards push the telescopic dome shaft into the adapter and adapt it to the planned area surface.

1 Adapter = max. earth-cover 1200 mm

(in each case in connection with the Maxi telescopic dome shaft)

- ① Telescopic dome shaft (can be inclined by 5°)
- ② Adapter
- ③ Tank dome (can be rotated by 360°)

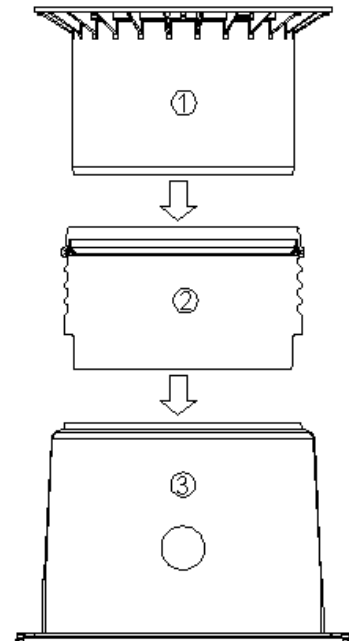

7. Inspection and servicing

The entire system must be checked for leaks, cleanliness and stability at least every three months.

The entire system should be serviced at intervals of approx. 5 years. In this case, all parts of the system must be cleaned and their function checked. Servicing should be carried out as follows:

- Drain the tank completely
- Clean surfaces and internal parts with water
- Remove all dirt from the tank
- Check that all internal parts are firmly seated.